

Planting Guidelines on Council Green Verge by Residents

Purpose

The Guidelines to provide information and advices for residents who wish to beautify their home frontage, which is only confined to the green verge immediately in front of their houses.

Objective

The objective of these Guidelines is to support the provision of safe, environmentally sustainable and aesthetically pleasing verge. Any planting on residents' home frontage shall comply with these guidelines. Residents shall obtain permission from the Council for any planting work which they wish to carry out.

Planting on Green Verge

The Council requires that any planting on green verge by residents shall complies with the following conditions:

1. Area allowed for planting is **confined to the green verge immediately in front of the houses** only.
2. **Trees of any type shall not be planted** by residents on the Council's green verge.
3. **All types of vegetables shall not be planted** on the Council green verge.
4. Only palms, shrubs and groundcover are allowed to be planted. Plants are required to be selected to suit to soil condition, location and function.
5. Residents are not allowed to plant any type of plant except turf grass **within six meters (6 m) radius from road junction**.
6. Residents are not allowed to plant any kind of plant except turf grass on **green verge with width less than one and half meters (1.5m)**.
7. Residents shall comply to the vegetation clearing profile by Syarikat SESCO Berhad as attached in Appendix A.
8. Residents shall do **regular maintenance** on the planted plants including prune and trim those planted plants so that it does not obstruct the movement and visibility of pedestrians and motorists, to remove all fallen leaves and fronds, grass cutting and etc.
9. All garden waste arises from the maintenance work shall be disposed inside mobile garbage bin (MGB) or properly bagged in a disposable bag, placed next to the MGB. Any additional cost arises from disposing of garden waste shall be borne by the residents.

10. Residents may refer to the recommended plants as attached in Appendix B: Plants Listing for planting on green verge.
11. **Spiny and thorny plants** such as Cacti, Agave and large Pandanus species **should not be planted** as these may cause injury to unwary pedestrians or children.
12. Plants that are untidy growing habit such as **sugarcane, papaya, bananas and bamboos should not be planted** as these will obstruct the pedestrian walkway.
13. **Coconut tree shall not be planted** as the coconut fruit falling from the tree might strike individual or property and cause serious injury or damages to them.
14. Avoid placing planted containers or pots on the footpath or on the road as this will obstruct pedestrians.
15. Residents are **not permitted** to construct structure such as fence, walls and etc on verge or change the existing roadside elements such as remove road kerb, scupper drains and etc.
16. Residents are **not permitted** to remove any existing Council's landscape plants and trees on verges to plant their own plants.
17. Any plant which post traffic hazard, threaten public safety or no adequate maintenance **will be removed by the Council without notify the owner.**
18. Residents are encouraged to take out, at its own cost and expense, the public liability insurance policy to insure themselves on any plant planted by them on green verge against any claim(s), suit(s), actions or demand made against them, by any member of the public for any damage or injury caused to him or his property either directly or indirectly by those plants planted by them.
19. Residents shall reinstate any damage caused to the Council's infrastructures, landscaping or other public utilities as a result of the planting and/or landscape maintenance activities at their own cost.
20. Any future maintenance or upgrades of Council or any essential service infrastructure require the plantings to be removed, no compensation will be due for the removal of any plants planted on green verge.
21. Residents shall apply for planting on green verge in writing on the attached application form (Appendix C), and must not be proceeded with until written approval is received from the Council.

Planting on Council Green Verges: Do's and Don'ts



Prune and trim planted plants regularly



No maintenance



Spiny and thorny plants such as Cacti, Agave and large Pandanus species should not be planted



Plants that are untidy growing habit such as sugarcane, papaya, bananas and bamboos should not be planted



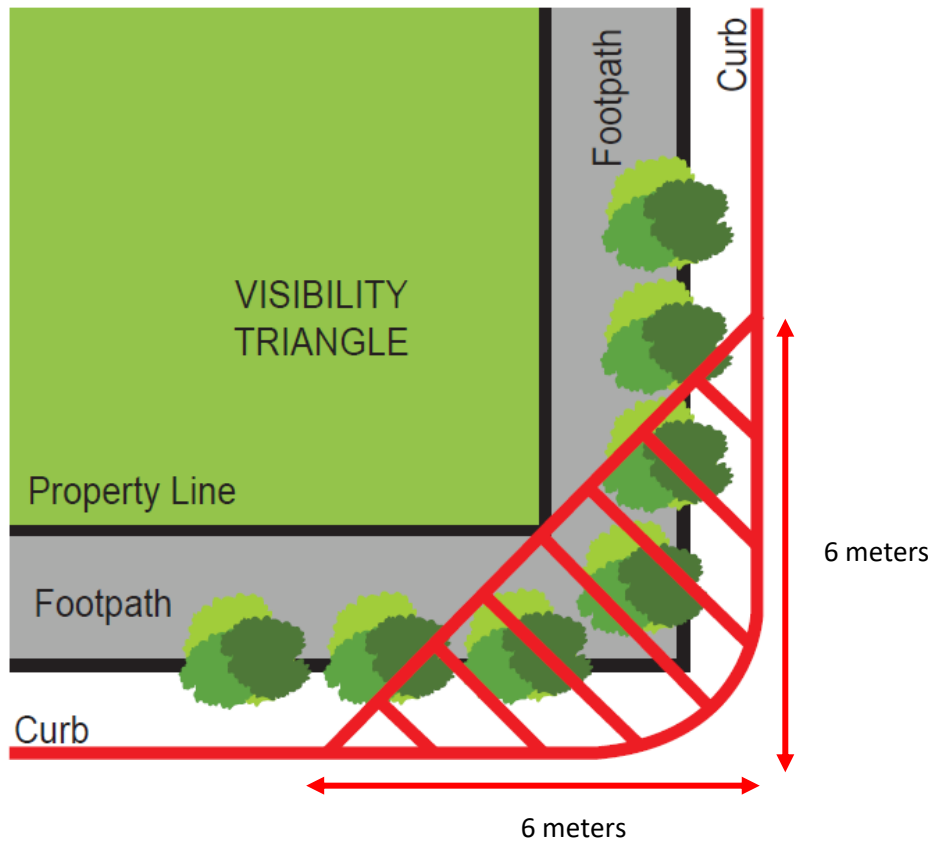

No planting is allowed **within six meters (6 m) radius from road junction**

Vegetation Clearing Profile

The cutting Shall encompass clearance zone as defined below:

Direction	Clearances from Mains (m)	
	Standard Profile	
	HT	LT/HT Aerial Bundle Cable
Side	6.0	3.0
Above	4.0	2.0
Below	Cleared to 1m from flat / even ground or 5.2m from the lowest LT conductor on slopping ground	Cleared to 1m from flat / even ground or 5.2m from the lowest LT conductor on slopping ground

Table 1: Vegetation Clearance

The same clearances are represented in the figures below for standard poles but shall also be applicable for HT towers and monopoles:

Figure 1 – Vegetation Clearing Profile High Tension (HT)

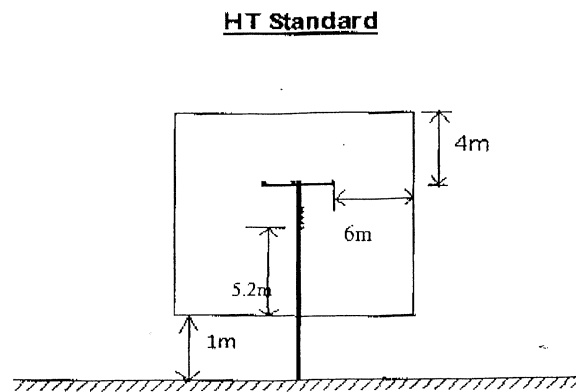
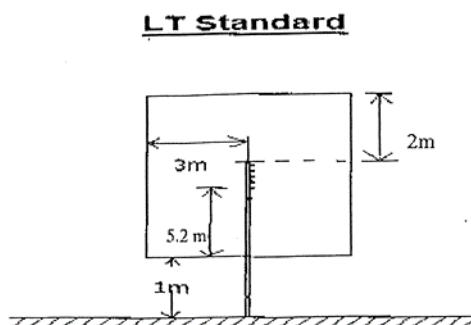

Figure 2 – Vegetation Clearing Profile Low Tension (LT)



Plants Listing

Featured below are some of the recommended plants that residents can use for planting on the Council green verges:

Palms



Phoenix roebelenii

Common Name:
Pygmy Date Palm



Adonidia merrillii

Common Name:
Manila Palm



Rhaps excelsa

Common Name:
Lady Palm



Cycas sp.

Common Name:
Cycad



Dypsis lutescens

Common Name:
Yellow Cane Palm



Hyophorbe lagenicaulis

Common Name:
Bottle Palm



Bentinckia nicobarica

Common Name:
Bentinck Palm



Wodyetia bifurcate

Common Name:
Foxtail Palm



Cyrtostachys renda

Common Name:
Sealing-wax Palm

Shrubs



Acalypha sp. (Acalypha siamensis)

Common Name:
Tea Leaves



Allamanda sp. (Allamanda cathartica)

Common Name:
Golden Trumpet



Brunfelsia pauciflora

Common Name:
Yesterday, Today
and Tomorrow



Duranta sp. (Duranta erecta 'Gold Edge')

Common Name:
Golden Dew Drop



Ixora sp.

Common Name:
Bunga Jenjarum



Alternanthera dentata

Common Name:
Brazilian Red



Murraya paniculate

Common Name:
Kemuning



***Gardenia jasminoides* 'Absolute'**

Common Name:
Cape Jasmine



***Bougainvillea* sp.**

Common Name:
Bunga Kertas



Hibiscus sp.

Common Name:
Hibiscus



Plectranthus scutellarioides

Common Name:
Coleus



Turnera ulmifolia

Common Name:
West Indian Holly



Vinca sp.

Common Name:
Periwinkle



Cordyline sp.

Common Name:
Dracaena



Crinum asiaticum

Common Name:
Crinum Lily



Lagerstroemia indica

Common Name:
Crepe Myrtle

Groundcovers



Portulaca sp.

Common Name:
Japanese Rose



Pandanus sp.

Common Name:
Dwarf Screw Pine



Ophiopogon sp.

Common Name:
Mondo Grass



Cyathula sp.

Common Name:
Hookweed



Zephyranthes sp.

Common Name:
Rain Lily



Tradescantia spathacea

Common Name:
Boat Lily



Majlis Bandaraya Kuching Selatan

APPLICATION FOR PLANTING ON COUNCIL GREEN VERGES

APPLICATION

Summit to: Building and Landscaping Division, Tingkat 1, Majlis Bandaraya Kuching Selatan, Jalan Padungan, 93675 Kuching Sarawak.

or

Scan (pdf) and Email to: request@mbks.gov.my

Name of Property Owner/s:

.....
.....

I hereby apply for permission to plant the verge area of the property I own:

Property Address:

.....
.....
.....

Postal address:

.....
.....
.....

Telephone-(H):..... (Mobile):..... Other:

PLANTING ON COUNCIL VERGE: TERMS AND CONDITIONS

The Applicant agrees to the following:

1. To ensure that the planting within the verge will not create a public risk.
2. To ensure that the planting do not cause sight-line issues for vehicles, cyclist or pedestrians.
3. To indemnify Council against all actions/claims whatsoever for bodily injury and/or damage to property arising out of the development and/or maintenance of the verge (excluding plant undertake by the Council).
4. To bear all the costs and liabilities of the landscaping work and responsibility for the landscape plants.
5. To accept full responsibility for the maintenance of the verge. If the verge planting is not maintained to the satisfaction of the Council, it will be removed without any notice.
6. To comply to all general rules stated in the Planting Guidelines on Council Green Verge by Residents.
7. To maintain any planted plants regularly and dispose-off any garden waste properly and not left on the green verge.
8. To reinstate any damage caused to the Council's infrastructures, landscaping or other public utilities as a result of the planting and/or landscape maintenance activities at their own cost.
9. Any future maintenance or upgrades of Council or any essential service infrastructure require the plantings to be removed, no compensation will be due for the removal of any plants planted on green verge.

Intent of works (detailed of the proposed works, plant species and materials to be used): attach sketch plan and photos are recommended

.....
.....
.....
.....
.....
.....
.....
.....
.....
.....

I have read and agree to the terms and conditions for the planting and maintenance of the verge area, and agree that all works will comply with the Planting Guidelines on Council Green Verge by Residents and will commence only following written approval from the Council.

Signature of Property Owner/s:

.....

Date:.....

OFFICE USE ONLY

Approved/Not Approved

Name:

Signed:

Position:

Date:

Conditions:



Majlis Bandaraya Kuching Selatan

Undertaking from Planting on Council Green Verge

I, Mr. / Ms.(property owner) with phone number(h/p) (home) hereby to undertake the plants which planted on green verge fronting my property at
.....
.....(as photo attached).

I further agree to follow the terms and conditions stated below:

1. To ensure that the planting within the verge will not create a public risk.
2. To ensure that the planting do not cause sight-line issues for vehicles, cyclist or pedestrians.
3. To indemnify Council against all actions/claims whatsoever for bodily injury and/or damage to property arising out of the development and/or maintenance of the verge (excluding plant undertake by the Council).
4. To bear all the costs and liabilities of the landscaping work and responsibility for the landscape plants.
5. To accept full responsibility for the maintenance of the verge. If the verge planting is not maintained to the satisfaction of the Council, it will be removed without any notice.
6. To comply to all general rules stated in the Planting Guidelines on Council Green Verge by Residents.
7. To maintain any planted plants regularly and dispose-off any garden waste properly and not left on the green verge.
8. To reinstate any damage caused to the Council's infrastructures, landscaping or other public utilities as a result of the planting and/or landscape maintenance activities at their own cost.
9. Any future maintenance or upgrades of Council or any essential service infrastructure require the plantings to be removed, no compensation will be due for the removal of any plants planted on green verge.

Agreed by:

 (Signature of owner)
 I/C Number: _____
 Date: _____
 Time: _____